

TABLET INSPECTION MACHINE :

TABLET INSPECTION MACHINE is one of the best options to ensure that the defective tablets and capsules will be rejected before leaving the manufacturing area, and only best quality tablets and capsules will be packed for being delivered to the consumers.

Special Features :

- Ce Certified Design With All Electrical Safety Compliances.
- Compact Design And All Contact Parts In S. S. 316 To Meet Cgmp Guidelines.
- No Change Parts Required For Various Shapes And Sizes Of Tablets / Capsules
- Specially Designed Technique For 360 Rotation Of Products.
- Adequately Illuminated Inspection Zone For Easy And Strain Free Inspection .
- Very Easy To Install , Operate And Maintain.
- Food Grade Material Used For Plastic And Rubber Components.
- Warranty Provided On All Moving Parts To Meet Safety Norms.
- Maintenance-Free Components Used To Minimize The Downtime And Maximize The Output.
- Quick And Efficient Cleaning With Standard Cleaning Agents.
- Combi Machine Suitable For Tablets And Capsules.

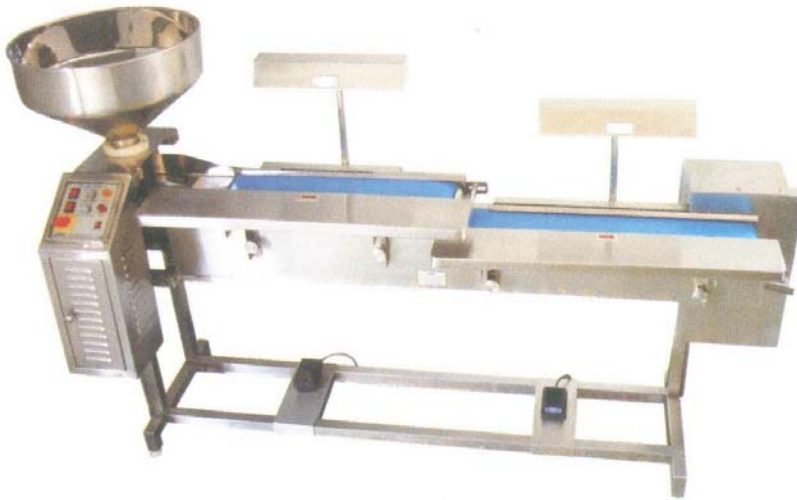

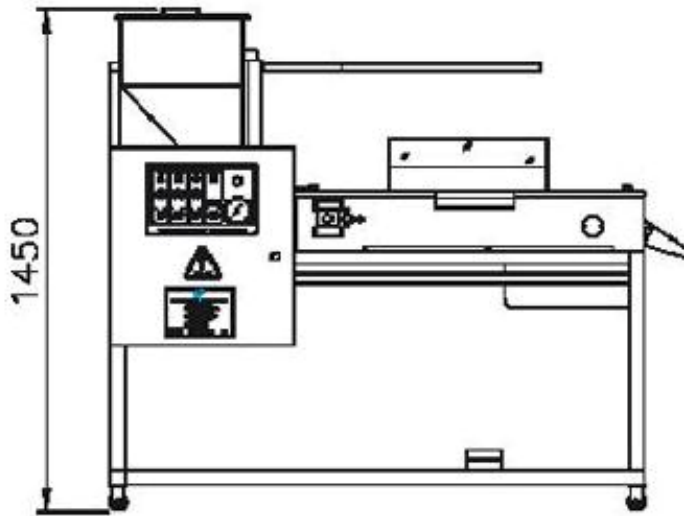

ELEVATION

- 2 -

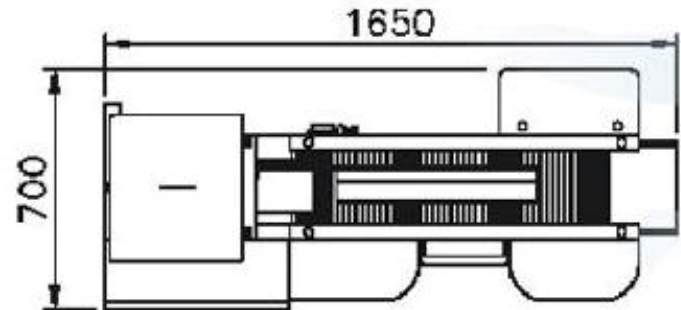

PLAN

Technical Data : Tablet Inspection :

Model No.	Power Supply	Conveyor Drive	Roller Drive	Conveyor Speed Regulator	Roller Speed Regulator	Vibrator	Illuminator	Weight
TCI	230V, 50Hz AC	1/4 Hp Bonfiglioli geared motor	1/4 Hp Bonfiglioli geared motor	0.4 KW / 0.5 HP, 220 V AC Drive	0.4 KW / 0.5 HP, 220 V AC Drive	Vibrotechnic make 230 V AC with regulator	Electronic Choke Tube light	150 Kgs. Aprox.

Note : Images Shown here are illustrative. As the design & manufacturing of Machines are subject to improvement, the product supplied will be as per our Techno-Commercial offer.